

B&P APPLIED SOLUTIONS

CASE: RST SEAL

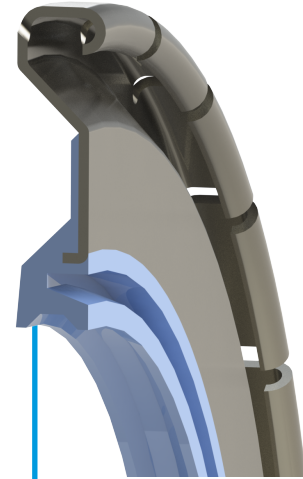

CONTEXT OF THE PROBLEM

Place

Argentina and other countries?

Application:

Agricultural

Use conditions:

It is a seal model implemented by our radial ball bearings that require greater shielding from contamination.

Customer need:

B&P bearings with "RST" design seals have achieved longer service hours in different applications.

Previously used product:

Seals with low contact and therefore less torque.

B&P RECOMMENDATION

The use of B&P bearings with this seal model, designed and patented specifically for high performance in aggressive pollution environments have given multiple advantageous results over the years.

- ▶ The results obtained against other options have been far superior

RESULTS

▶ For the farmer:

- Significantly longer bearing life, requiring less costs and maintenance tasks.
- Reduction of failures during service.
- The bearing is offered in the same standardized dimensions.

▶ For the manufacturer:

- For agricultural machinery factories, for example, the use of this model of bearings is substantial for the applications that require it, since it is being implementing a piece designed for the field, as well as for other of such conditions.
- Improving their competitiveness by offering a guarantee to your customers, equivalent to the offer in the market. And also with a product with availability and easy delivery.
- Reinforcement of their brand image in the market, offering products of superior quality, and with a greater technical advance.



Reinforced tightness



High load capacity



Wear resistance



Reduced maintenance intervals
Less service interruptions